

FACULTY OF ELECTRICAL ENGINEERING			
Subject:	ELECTRONIC DESIGN LABORATORY	Review : 2	Release Date : 2020
Subject Code:	SKEE 2752	Last Amendment : 2013	Procedure Number : PK-UTM-FKE-(0)-10



UTM
UNIVERSITI TEKNOLOGI MALAYSIA

Faculty of
Electrical Engineering

SKEE 2752

BASIC ELECTRONIC LAB

EXPERIMENT 3

LINEAR AND NON-LINEAR APPLICATION OF OP-AMP

Disediakan oleh Nama : PM Dr Norlaili Mat Safri PM Ir Dr Nasrul Humaimi Mahmood PM Ir Dr Azli Yahya PM Ir Dr Eileen Su Lee Ming Ir Dr Fauzan Khairi Che Harun Ir Dr Zaharah Johari Dr Mohd Azhar Abdul Razak Dr Mastura Shafinaz Zainal Abidin Dr Nurul Ezaila Alias Dr Mitra Mohd Addi Dr Fatin Hamimi Hamat @ Mustafa Dr Nurul Ashikin Abdul Kadir Hj Muhammad Arif Abdul Rahim	Disahkan oleh : Ketua Jabatan Nama : Prof. Ir. Dr. Rubita Sudirman <div style="text-align: center;">  PROFESOR IR. DR. RUBITA BINTI SUDIRMAN Director Department of Electronic and Computer Engineering Faculty of Electrical Engineering Universiti Teknologi Malaysia 81310 UTM Johor Bahru, Johor </div> Tandatangan : Cop :
Tarikh : September 2024	Tarikh : September 2024

OBJECTIVES :

- To construct and test inverting, summing, and difference amplifiers using op-amps.
- To construct and test an op-amp comparator and Schmitt Trigger.

PARTS AND EQUIPMENT:

- DC Power Supply
- Oscilloscope
- Function Generator
- LM 741 Op-amp
- Resistors
- Protoboard
- LEDs

THEORY:

Op-amp operations are classified into two: linear applications of op-amp and non-linear applications of op-amp. The output voltage or current is directly proportional to either input voltage or current are called linear op-amp circuits. A non-linear op-amp is one in which the output signal is not directly proportional to the input signal.

Op-amp is a very high gain amplifier with inverting and non-inverting inputs. One of the most important ideas in electronics incorporates the idea of feedback, where a portion of the output is returned to the input. If the return signal tends to decrease the input amplitude, it is called negative feedback. On the other hand, if the return signal tends to increase the input amplitude, it is called positive feedback.

In linear applications, op-amp works in amplifier mode which is obtained by a negative feedback to the op-amp. Examples of linear application of op-amp are inverting amplifiers, summing amplifiers, and difference amplifiers. In non-linear applications, op-amp works in switching mode which is obtained by a positive feedback or without feedback to the op-amp. Non-linear operation occurs when the op-amp output reaches either positive saturation or its negative saturation. Examples of non-linear application of op-amp are voltage comparators and Schmitt triggers.

PRE-LAB

Note:

- i. This pre-lab must be done before lab session and will be collected in the beginning of lab session.
- ii. For the simulation work, use LM741 or AD825 or COMPARATOR_VIRTUAL if OP-AMP 741 not available

PART 1: Inverting Amplifier

For the inverting amplifier circuit of Figure 3.1, derive the output equation, v_o , for the two extreme cases of R_x .

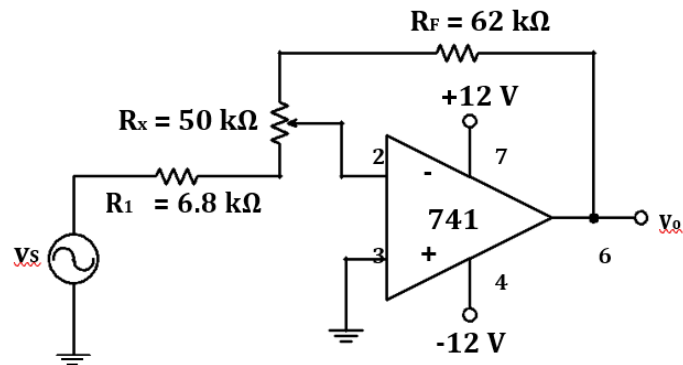

Figure 3.1

PART 2: Inverting Summing Amplifier

For the inverting summing amplifier circuit of Figure 3.2,

- Derive the output equation, v_o .
- Get the mathematical expression for the output waveform, v_o given in Figure 3.3.

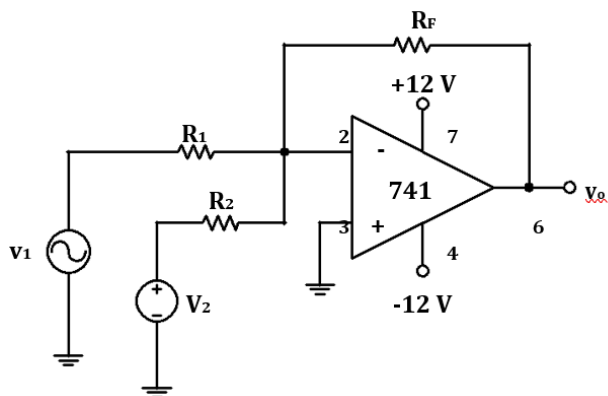

Figure 3.2

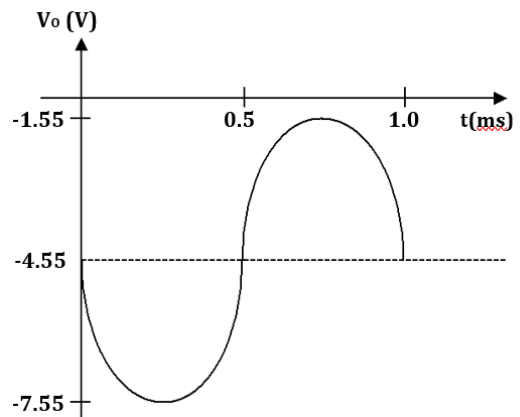

Figure 3.3

- Determine the value of R_1 and R_2 when R_F is equal to $100 \text{ k}\Omega$ and v_1 is a sine wave or square wave of 1 V_{pk} with a frequency 1 kHz and V_2 is a DC voltage of 5 V . (Hint: Use answer in (b)).
- Based on the values obtained in part (c), generate the output voltage waveform, v_o for the circuit of Figure 3.2 using Multisim. Print out the instrument connection and curve plot as a function of voltage (V) against time (t). Highlight the important measurement readings.

PART 3: Non-Inverting Summing Amplifier

For the non-inverting summing amplifier circuit of Figure 3.4,

- Simulate the circuit using Multisim or of any equivalent software. Set the v_1 to 8 Vpk sine waveform at 1 kHz and v_2 to 1 Vpk sine waveform at 50 kHz.
- Generate the output voltage waveform using Multisim. Set the timebase scale to 200 $\mu\text{s}/\text{Div}$ and the channel scale to 5 V/Div. Print out the instrument connection and the curve plot as a function of amplitude against time.
- Discuss the effect of different frequencies used.
- Save the circuit for later use in Part 5 and Part 6.

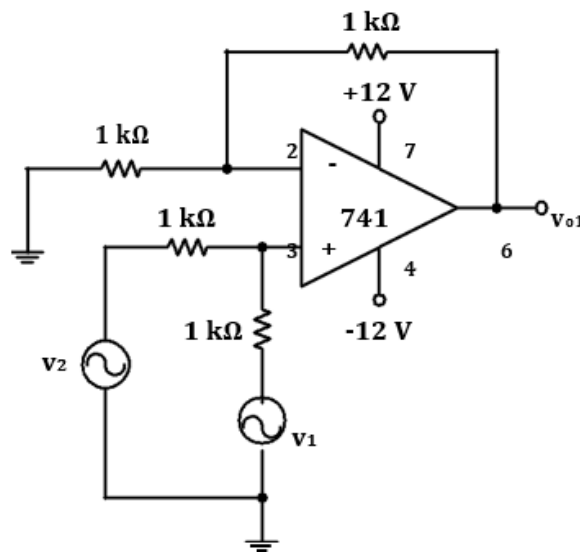

Figure 3.4

PART 4: Difference Amplifier

For the difference amplifier circuit of Figure 3.5,

- Derive the output equation, v_o .
- Generate the output voltage waveform using Multisim if v_1 is a sine wave or a square-wave of 1 Vpk, and V_2 is a DC voltage of 5 V. Print out the instrument connection and the curve plot as a function of amplitude against time. Highlight the readings that could verify your answer in part (a).

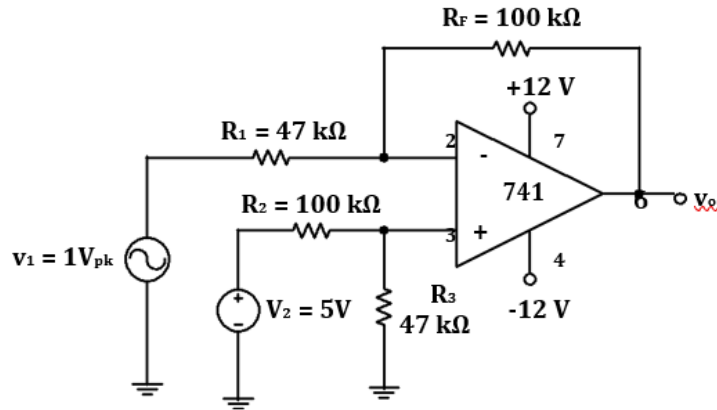

Figure 3.5

PART 5: Schmitt Trigger

For the schmitt trigger circuit of Figure 3.6,

- Derive the equation for V_{UTP} and V_{LTP} of the given circuit in Figure 3.6.
- From the given values of Upper Threshold Point, V_{UTP} and Lower Threshold Point, V_{LTP} in Figure 3.7, determine the values of R_1 and R_2 if the sum of R_1 and R_2 is equal to $68.8 \text{ k}\Omega$ and $V_{REF} = 5 \text{ V}$.
- Simulate the circuit in Figure 3.6 using Multisim if the input voltage, v_s is the output waveform of Figure 3.4 and V_{REF} is a DC voltage of 5 V . Print out the curve plot as a function of voltage (V) against time (t) and the transfer curve (v_o vs v_s) by clicking B/A on the oscilloscope.
- Discuss your observation on the output waveform.

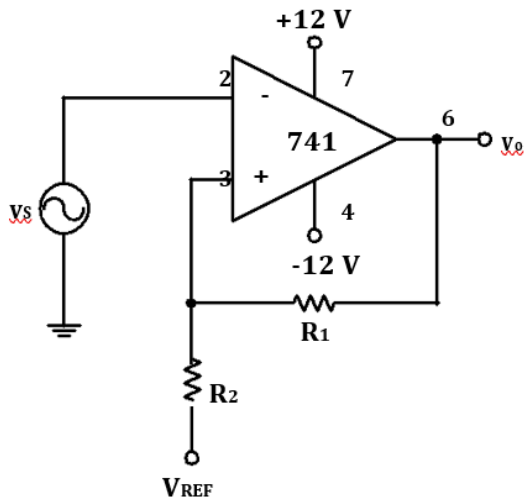

Figure 3.6

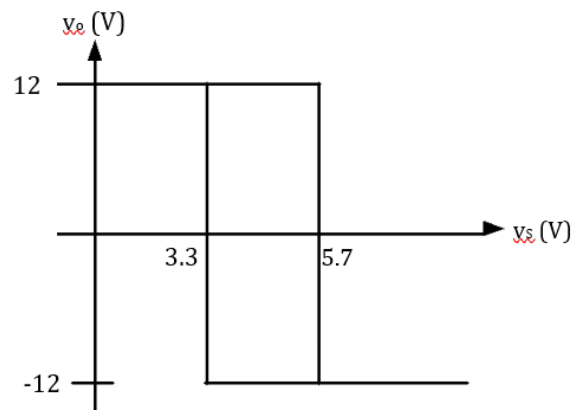

Figure 3.7

----- End of pre-lab activity -----

IN-LAB PROCEDURES

Part 1: Inverting Amplifier

1. Construct the circuit in Figure 3.1.
2. Set the input voltage, v_s to $2 V_{pk}$ (sine wave) with a frequency of 1 kHz.
3. Adjust the potentiometer from minimum to maximum values. Observe the output waveform.
4. Measure and record the output voltage for 3 different values of potentiometer (minimum, middle, and maximum values).
5. Discuss what you observed in this experiment.

Part 2: Inverting Summing Amplifier

1. Construct the circuit in Figure 3.2 with the values of R_1 and R_2 obtained from your pre-lab.
2. Set the input voltage, v_s to $1 V_{pk}$ (sine wave) with a frequency of 1 kHz.
3. Record the output voltage, v_o and observe the phase difference between the input and output. (Note the DC level in the output)
4. Compare your simulation with the experimental results.

Part 3: Difference Amplifier

1. Construct the circuit in Figure 3.5.
2. With v_s adjusted to produce a 1 V peak sine wave at 1 kHz, observe the output voltage v_o (and v_s to note the phase relationship) on an oscilloscope set to dc input coupling.
3. Record the output voltage waveform. Be sure to note the dc level in the output.

Part 4: Schmitt Trigger

1. Construct the circuit in Figure 3.6 with the values of R_1 and R_2 obtained from your pre-lab.
2. Set the input voltage, v_s to $8 V_{pk}$ (sine wave) with a frequency of 1 kHz and observe the output waveform on an oscilloscope. Use $V_{ref} = 5V$. (Note: The input coupling of both channels should be set to DC)
3. Sketch the input, v_s and output voltage, v_o in Table 3.1 (Note the level of v_s at which the output voltage, v_o changes level (V_{UTP} and V_{LTP})).
4. Identify the transition points (V_{UTP} and V_{LTP}).
5. Compare your simulation with the experimental results
6. Repeat steps 2 & 3 with input voltage, v_s values of 4V and 1V and record your results in Table 3.1.

GROUP NO:

Table 3.1

	$v_{S(pk)} = 8V$	$v_{S(pk)} = 4V$	$v_{S(pk)} = 1V$
v_o and v_s			
Transfer Curve			

SUPERVISOR's NAME : _____
SIGNATURE : _____

DATE : _____