

Faculty: FACULTY OF ELECTRICAL ENGINEERING	
Subject : ELECTRICAL ENGINEERING LABORATORY	Review : 4 Release Date : 13 September 2017 Last Amendment : 23 October 2022
Subject Code : SKE 3732/SKE3712	



UTM
UNIVERSITI TEKNOLOGI MALAYSIA

**FACULTY OF ELECTRICAL ENGINEERING
UNIVERSITI TEKNOLOGI MALAYSIA
JOHOR BAHRU
JOHOR**

SKE 3732/3712

**INSTRUMENTATION LABORATORY
LINEAR DISPLACEMENT MEASUREMENT**

Prepared by : 1. Mohamad Shukri Bin Abdul Manaf Signature & Stamp : Date:	Approved by: DIRECTOR Control and Mechatronics Engineering Division (CMED) Name : Assoc. Prof. Ts. Ir. Dr. Mohamed Sultan Bin Mohamed Ali Signature & Stamp : Date:
--	--

PRELIMINARY EXERCISE (15 marks)

Important Note: You are required to do this exercise BEFORE the lab session.

1. Explain what is loading effect in measurement.
2. Draw the connection using the potentiometer shown in Figure(i) as a voltage divider.
3. The resistance value in Figure (i) are $R_1 = 5\text{ k}\Omega$, $R_2 = 5\text{ k}\Omega$ and $R_3 = 5\text{ k}\Omega$ respectively. Calculate the error of Moving Coil Meter if it has internal resistance $10\text{ k}\Omega$ and voltage supply (V_s) is 10V .

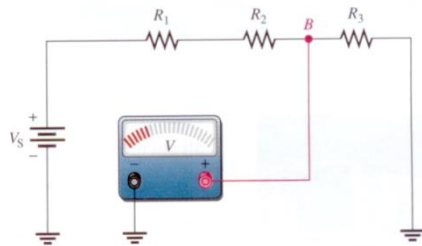

Figure (i)

4. Discuss the error in voltage measurement between low and high resistance circuit.
5. Briefly discuss the difference between a logarithmic and linear track.
6. Explain the input and output impedance of buffer circuit. What are the functions of buffer in instrumentation and measurement.

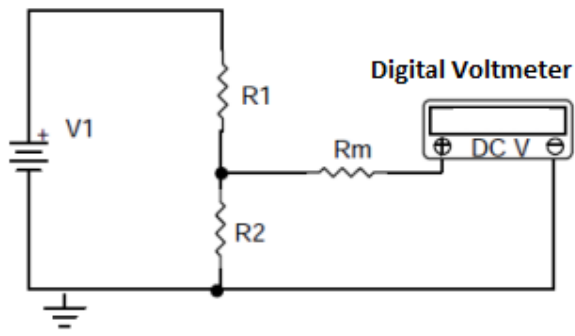

Figure 1

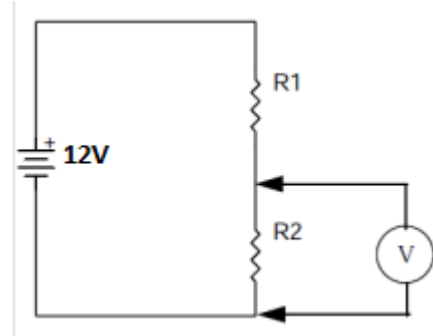

Figure 2

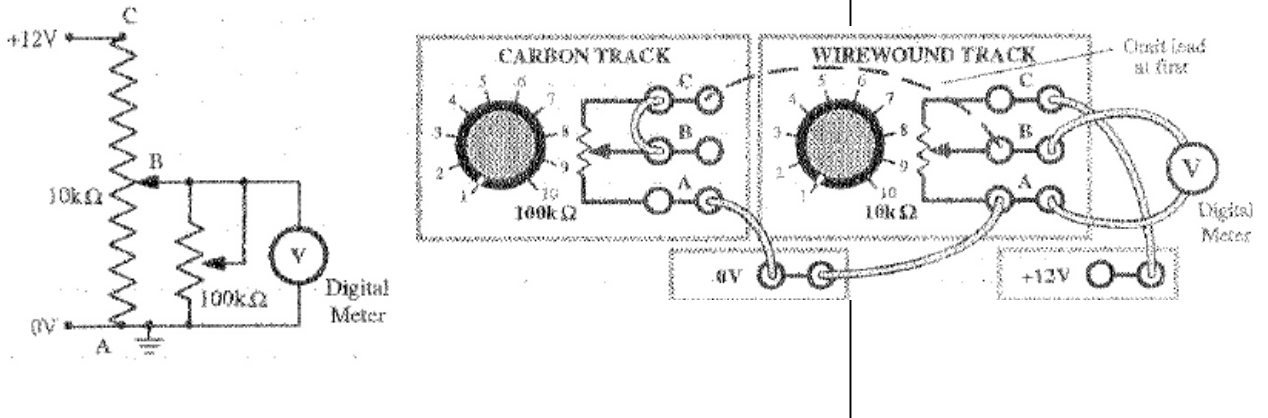

Figure 3

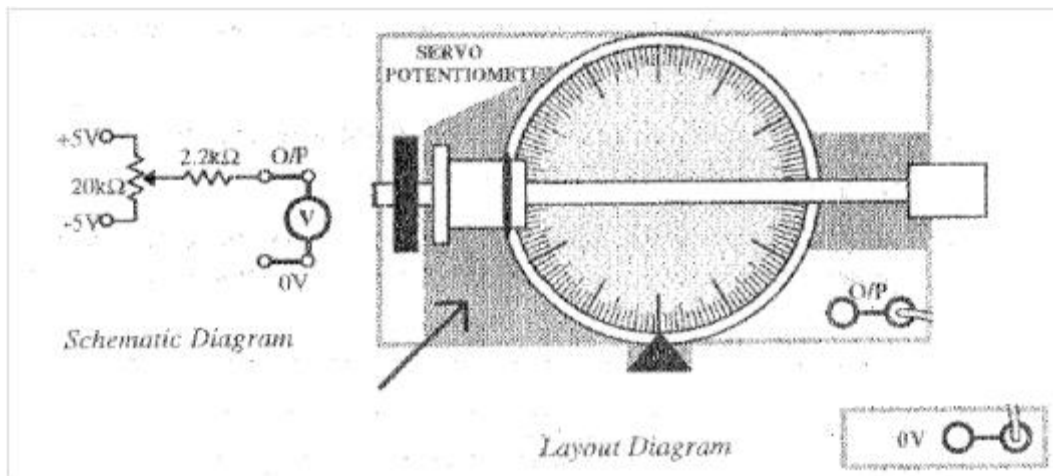

Figure 4

Objective

The objective of this experiment is:

- i. to measure the voltage in a simple dc circuit.
- ii. To determine the effects of adding a meter to a circuit under test.
- iii. To observe the effect on measurement accuracy when the circuit resistance changes relative to the meter resistance.
- iv. Sensor application and measurement.

Apparatus and Equipment:

DIGIAC 1750 (100k Ω Carbon track resistor, 10k Ω Wirewound rotary resistor, 10k Ω Carbon track slider resistor and 0-10V Moving Coil meter, servo potential meter and buffer), Connecting Leads.

Procedure

Background

Introducing a measuring instrument into any electric circuit causes a loading effect. This loading effect is due to the internal resistance of the instrument's circuits. This resistance can have a fixed value or depend on the range setting of the instrument. Voltage measurement places the internal resistance of the instrument in parallel with the circuit element.

Perecaution

Make sure the voltage supply is **not directly** connected to ground or negative supply. Normally these happen when students modified a circuit or unintentionnally.

Experiment 1;

- 1) Measure the resistance of moving coil meter using digital meter and record the results.
- 2) Using 100k Ω Carbon Track resistors. Turn the knob (control setting) at the middle and measure a resistance R_1 and R_2 using Digital meter . Assume these resistances are accurate through the measurement using Digital meter. The position of knob 100k Ω Carbon Track resistors will be use in following step 3.
- 3) Construct the circuit in Figure 1 using 100k Ω Carbon Track resistors and $V_s=12V$. Use Multimeter to verified the voltage supply V_s . Measure the voltage accross R_2 using
 - a) moving coil meter.
 - b) Digital Voltmeter
 - a) Calculate the error compared the reading of Digital multimeter to theory (calculation)

Experiment 2;.

- 1) Construct the circuit in Figure 2 using 100k Ω Carbon Track resistors. Change the values of R_1 and R_2 by control knob (control setting).
- 2) Measure the voltage across R_2 using the
 - a) DVM only,
 - b) the moving coil only,
 - c) the moving coil and DVM connecting simultaneously
- 3) Record these values in Table at least 10 reading for each experiment.
- 4) Plot the graph and discuss the characteristic.

Experiment 3;.

- 1) Construct the circuit in Figure 2 using 10k Ω wirewound rotary resistors.
- 2) Repeat the steps 2 until 4 in the experiment 2.

Experiment 4:.

- 1) Construct the circuit in Figure 3 using 10k Ω wirewound rotary resistor and 100k Ω rotary resistors. Leave out the lead from contact C of the 100 k Ω resistor to contact B of 10k Ω , so that the load is not connected across the output..
- 2) Switch the power supply and adjust the 10 k Ω to give output 6V. Do not re-adjust the setting during this exercise.
- 3) Set the 100 k Ω resistor fully clockwise (knob scale 10) and connect the missing lead from contact C of 100 k Ω resistor to contact B of 10 k Ω so that the load is connected across the output of the positional sensor 10 k Ω .
- 4) Set the 100 k Ω knob (scale 1-10) and measure the voltage across B and A using the DVM and their resistance. Record these values in Table at least 10 reading for each experiment. Plot voltage output versus resistance value.

Experiment 5:.

- 1) Do not alter the setting of 10 k Ω set in experiment 4 . Remove 100 k Ω from circuit and connect as shown in figure 2. Measure the voltage using analog meter. By comparing graph in experiment 4, calculate resistance of moving coil. Compare reading with the experiment 1. Find the cause of error from theory and the reading differences. Suggest the procedure to conduct experiment above for minimising the error.

Experiment 6:.

- 1) From experiment 5, connect 10 k Ω wirewound resistor as shown in figure 2. Connect the voltage to buffer and Measure the voltage using analog meter then by multimeter. Compare the reading.

Experiment 7- Servo Potential meter

- 1) You are required to get a relationship of dial angle versus voltage output multimeter. Draw a connection. You can give an input $\pm 5V$ to servo potentiometer for this experiment.

Experiment 8- Application of resistive sensor and measurement.

- 1) Choose one type of resistive sensor. Suggest an application using the sensor and construct the circuit of signal conditioning. The signal conditioning may use of bridges, amplifier or other device on digiac 1750. The design should be sensitive to resistance changes.
- 2) Using Multimeter, measure necessary value due to physical parameter changes..
- 3) For both step 1 and 2, compare with theory and discuss on characteristic, resolution, accuracy, error and effect of your design circuit.

Discussion and general conclusion.

- 1) Plot reading in Graphs and Compare the result between using different meter in measurement.
- 2) Using the obtained data procedures and the theoretical value, determine the characteristic and sensitivity.
- 3) Discuss the error in measurement.
- 4) Calculate the correlation value of your graph characteristic.
- 5) Include all the data from the tables in the report. Include all the calculations in an appendix to the lab report.
- 6) The calculations should be done on engineering or graph paper.
- 7) Using the tables and graphs explain the loading characteristic of each instrument. Compare the loading characteristics and calculate correlation value of your graph characteristic.